

SSL INSTALL GUIDE

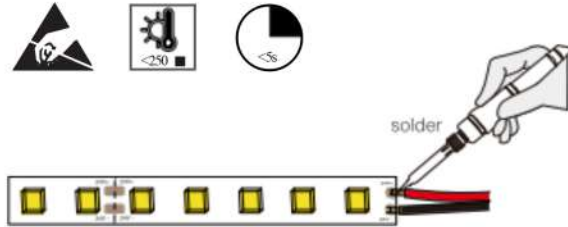

Connecting two welded parts with a maximum temperature of 250 ° C and no more than 5 seconds, and you must wear an electrostatic bracelet.

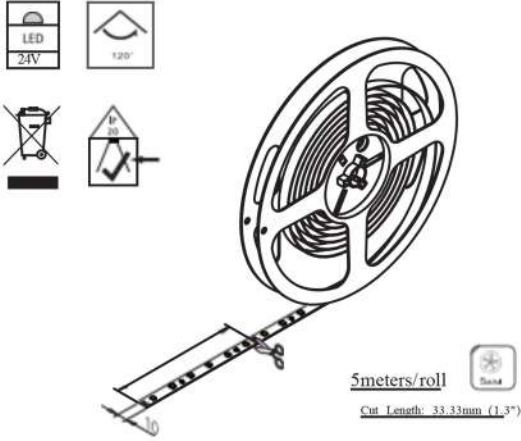
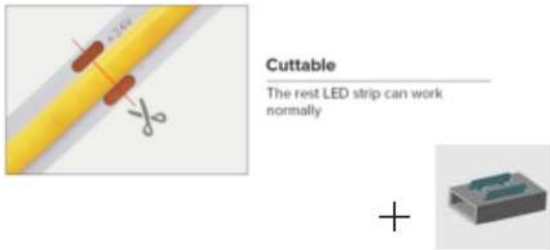

Cut along the LED Flex strip wherever a dashed line divides two sets of positive and negative connection points, and pls wear an electrostatic bracelet.

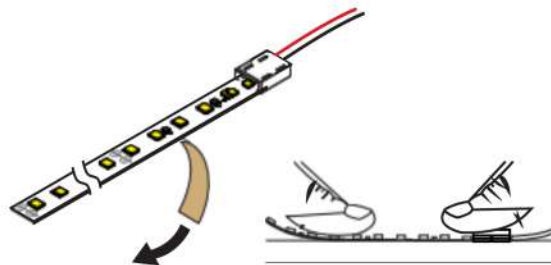
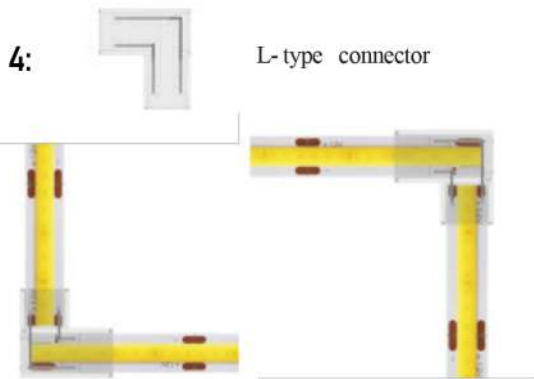
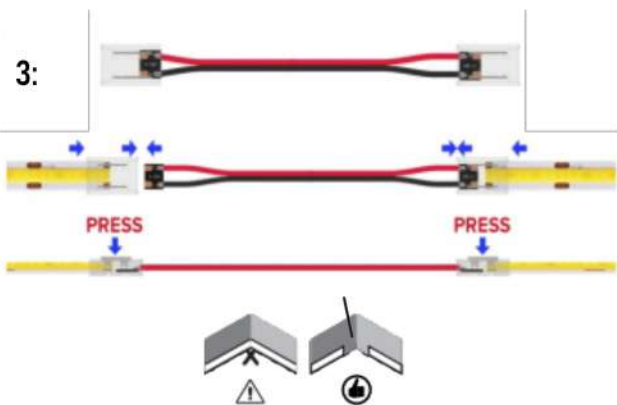
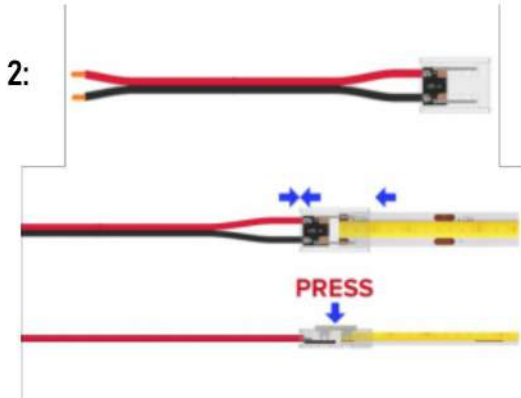
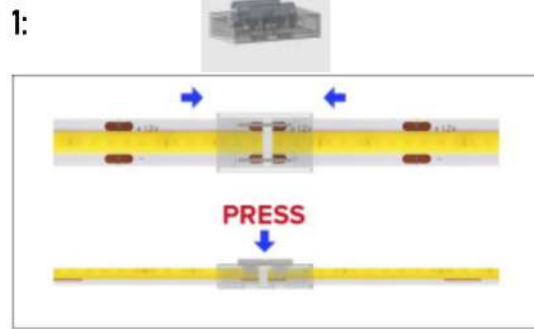

Remove the 3M tape from the connection and Ensure ambient temp is minimum 50 ° F (10 ° C) or tape will not adhere properly. Attach the strip to the installation position, and Adhere to a smooth, dry surface, working one end to the other.

Waterproof Rate :

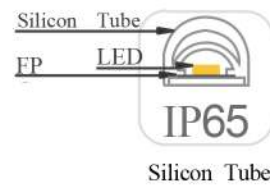
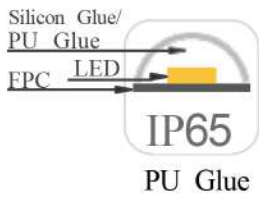
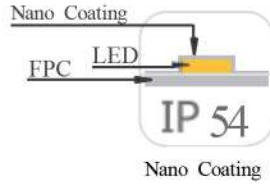
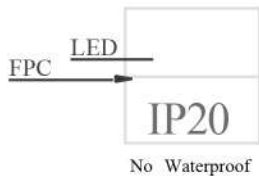

IP Rate Description :

- IP20 : Indoor use
- IP54 Nano : No Color shift with high Color Consistency
- IP65 PU : No Lead and mercury, Strong adhesion
- IP65 Silicon : Anti-UV ability, never become yellow
- IP67 : Silicon glue and mercury-free, Strong adhesion
- IP68 : PU glue with Anti-UV, never change color

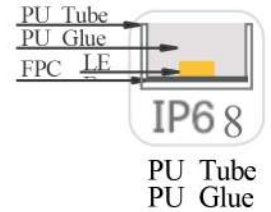
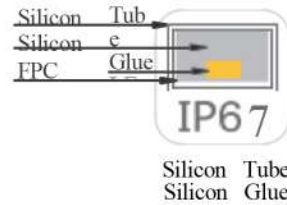

Wiring diagram application :

◆ Single end power input for 5 meters

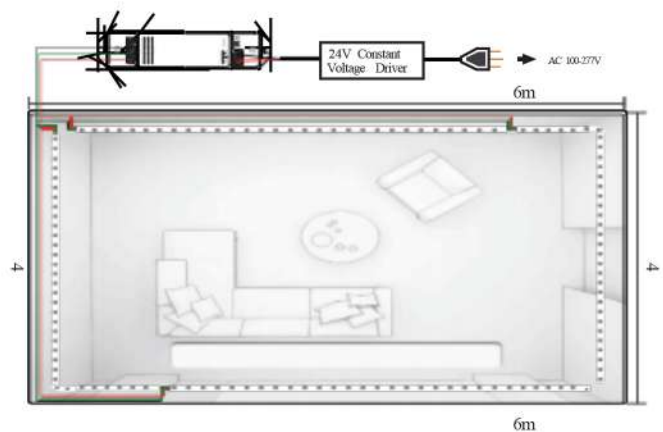
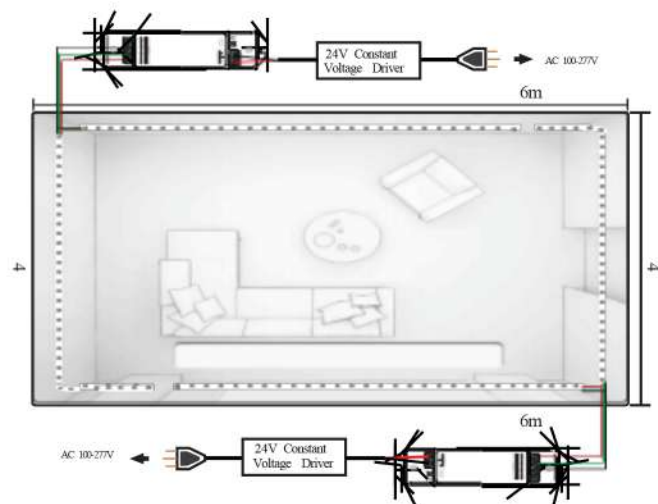
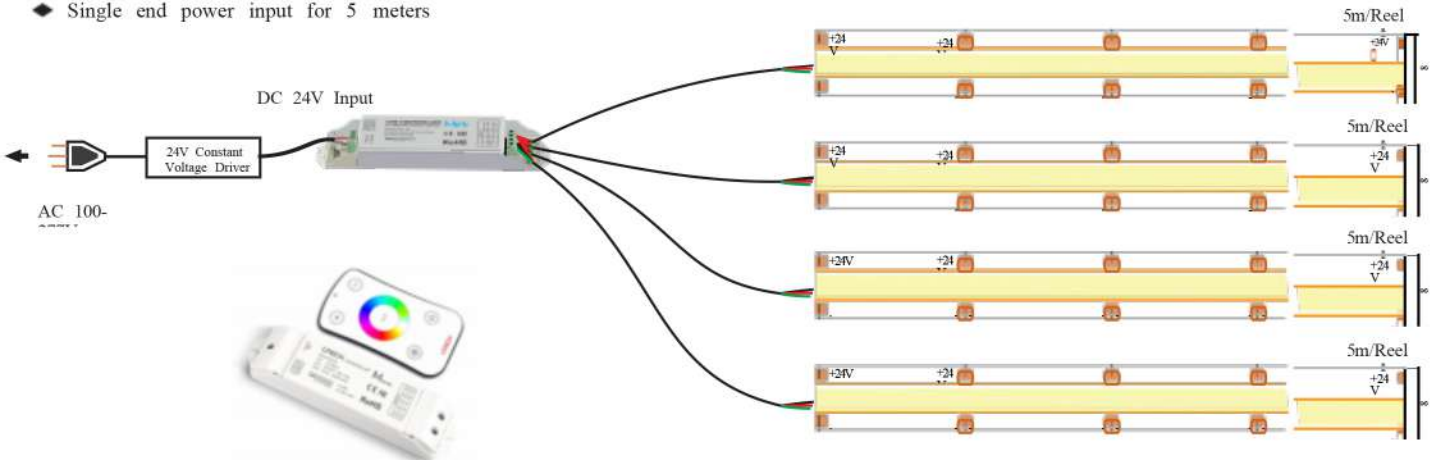

Operation Attentions:

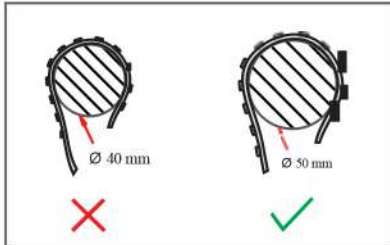

Do not bend LED Strip light to a diameter less than 40mm(1.5 inches)

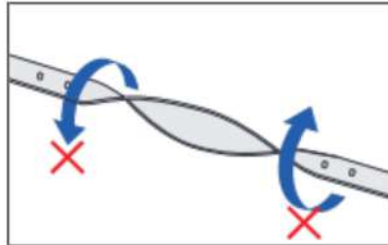

Do not bend LED Strip light like this, and this way will break the LED and bonding pad

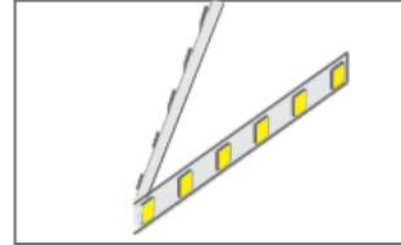

Do not fold or crease LED Strip light, and this way will break the LED and bonding pad

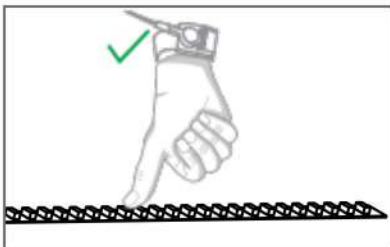

Touching LED, pls wear the electrostatic ring for avoiding ESD



Do not put press heavily or put excessive pressure on surface of LED

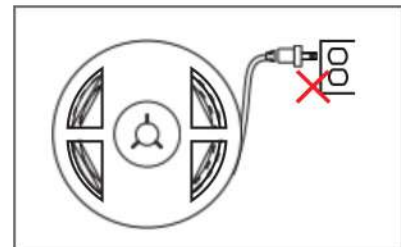

Do not connect directly LED Strip light to AC /DC high voltage power!

Safety Information:

- Please use 24VDC isolated power supply to drive the led strip, and the constant voltage source ripple less than 5%.
Can't step-down the power by resistance-capacitance and non-isolated power supply driver led strip, etc.
- To ensure the longevity and reliability of the strips, please do not bend the arc diameter 60mm or less, do not fold to avoid damaging the lamp beads or broken.
- To ensure the life and environment of lights, in the use of force can not pull the power cord to avoid damage to prohibit collision LED lights.
- During the installation of positive and negative attention to the power cord, do not pick the wrong voltage power supply and the product are the same, so as to avoid damage to the product.
- LED lights should be stored in dry sealed environment, the proposed storage period should not be too long before using unpacking, the working temperature: $-20 \sim +45$, Storage temperature: $-0 \sim +60$, not waterproof lights band indoor use, relative humidity not higher than 70%;
- In practical applications, the power supply should leave 20% margin (recommend using only 80% of the power) in order to ensure a sufficient amount of voltage drive products
- Do not use any acidic, alkaline adhesive securement products (including not limited to glass, plastic, etc.)