

Features

Cut-off Wall Pack - Large 90W & 135W

- Suitable for WET location/Outdoor
- Full Cutoff and compliance to Dark Sky requirement
- 90W-135W power consumption, to replace 250-400W MH
- Lumen output 9300-13000lm, CCT is 5000K
- Type III polycarbonate optical lens with UV stabilizers
- 120-277V
- Built-in UL class 2 driver, optional for photocell
- UL/cUL listed and DLC qualified



Applications

- Security, pathway and perimeter lighting
- Building entryways and walkways



Cut-off Wall Pack - Large 90W & 135W

Specification

Specification/ Model	NUR-WP-90W-5000K	NUR-WP-135W-5000K
Input Power	90W	135W
Lumens output	9500lm	14000lm
Efficacy	106lm/W	104lm/W
CRI	80	
Color Temperature	5000K	
Input Voltage	120VAC	
Finish Color	Dark Bronze	
Optical Lens	Polycarbonate (UL Recognized) (f1) Suitable for outdoor use with respect to exposure to Ultraviolet Light, Water Exposure and Immersion in accordance with UL 746C	
Mounting	Wall Mounting	
Photocell	120V-277VAC (UL and CSA listed) 3/4in long threaded nipple,30-45 second time delay, Power Consumption: less than 0.9 watts at 120 VAC	

Dimension

unit: inch/mm

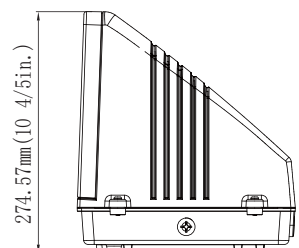
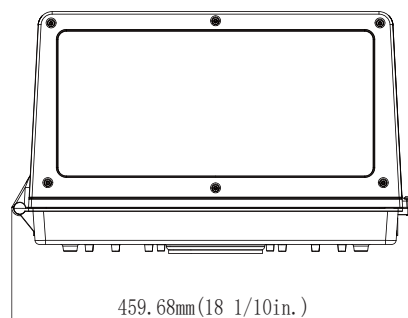



Cut-off Wall Pack - Large 90W & 135W

Energy Saving Replacement

MODEL	Replacing
90W LED	250W MH
135W LED	400W MH

Cut-off Wall Pack - Large 90W & 135W

Photometrics

90W

Luminous Intensity Distribution Curve

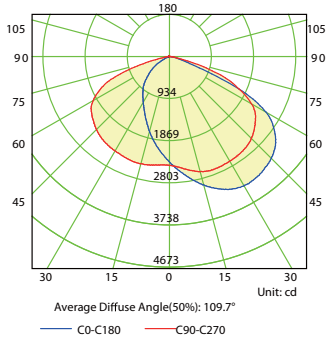

Illuminance at a Distance

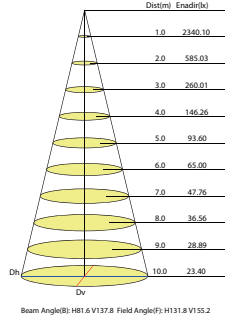

135W

Luminous Intensity Distribution Curve

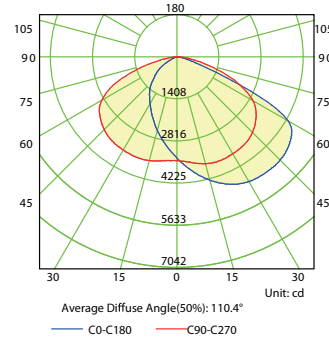

Illuminance at a Distance

